

1) CONSTRUCTION:

CONDUCTOR:	28 AWG 7/36 STRANDED TINNED COPPER	NOM. DIA.	.015"
INSULATION:	FOAMED FEP, .008" NOM. WALL THICKNESS		.031"
PAIRS:	COLOR CODED SINGLES TWISTED INTO PAIRS		.062"
CABLE:	(4) TWISTED PAIRS TWISTED TOGETHER TO FORM A CABLE CORE		
SHIELD:	AN ALUMINUM POLYESTER ALUMINUM FOIL SHIELD (100% COVERAGE) SHALL BE APPLIED OVER THE CABLE CORE AND SHALL INCLUDE A 28 AWG STRANDED TINNED COPPER DRAIN WIRE IN CONTACT WITH THE OUTER SURFACE.		.145"
JACKET:	LOW SMOKE POLYVINYLCHLORIDE, (COLOR, PER CHART 1), .021" NOM. WALL THICKNESS	OVERALL CABLE DIAMETER	.186" NOM. .191" MAX.

2) PHYSICAL PROPERTIES:

TEMPERATURE RATING, MAX.	105°C
TEMPERATURE RATING, MIN.	-20°C
WT./M', NOM., NET.	16.5 LBS.

CHART 1:

QUABBIN P/N	JACKET COLOR
2045	BLACK
2046	BROWN
2047	RED
2048	ORANGE
2049	YELLOW
2050	GREEN
2051	BLUE
2052	VIOLET
2053	GRAY
2054	WHITE
2055	STARLIGHT BEIGE

3) ELECTRICAL CHARACTERISTICS:

SEE PAGE 2

4) AGENCY APPROVALS:

NEC (ETL) TYPE CMP
CEC C(ETL) TYPE CMP

5) APPLICATION:

RoHS COMPLIANT MATERIALS. MEETS TIA 568.2-D CAT 6 CHANNEL REQUIREMENTS AT 54 METERS. 4.7 METERS OF PATCH CABLE WITH A 90 METERS PERMANENT LINK (94.7 METER CHANNEL) OR 10 METERS OF PATCH CABLE WITH AN 79 METER PERMANENT LINK (89 METER CHANNEL). SUPPORTS CAT 6 APPLICATIONS. PATENT PENDING.

6) PRINT: (WHITE INK ON BLACK JACKET, ALL OTHERS BLACK INK)

QUABBIN DATAMAX MINI-6 F/UTP PATCH CORD P/N (QWC P/N PER CHART 1) -- PATENT PENDING -- C(ETL)US TYPE CMP 28 AWG 105C -- RoHS -- (LOT DESIGNATOR) (SEQUENTIAL FOOTAGE)

7) COLOR CODE:

1. NATURAL X ORANGE
2. GRAY X BROWN
3. NATURAL X GREEN
4. GRAY X BLUE

8) PUT UPS

TO BE PACKAGED AS PER QWC'S STANDARD PACKAGING

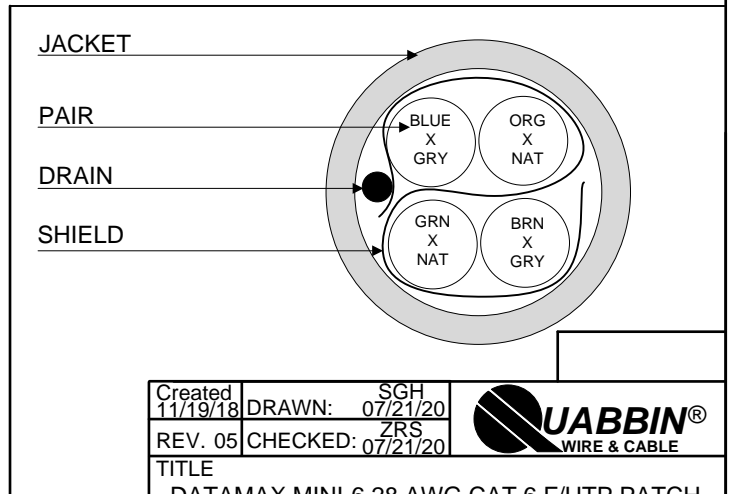

Created 11/19/18	DRAWN: SGH 07/21/20
REV. 05	CHECKED: ZRS 07/21/20



TITLE
DATAMAX MINI-6 28 AWG CAT 6 F/UTP PATCH CABLE – TYPE CMP

DRAWING# QWC0115 1 of 2

CUSTOMER APPROVAL:

DATE:

3) ELECTRICAL CHARACTERISTICS:

CAPACITANCE, MUTUAL, NOM.	13.5 PF/FT. AT 1 MHz
DIELECTRIC WITHSTANDING, MIN.	1500V RMS
VOLTAGE RATING, MAX.	300V
D.C. RESISTANCE, NOM.	22.4 Ω /100m (68.2 Ω /1000')

NOTE: TESTING FOR THE FOLLOWING IS CONDUCTED OFF THE REEL, USING 50m LENGTHS. (FOR 100m OF CABLE)

IMPEDANCE	100 \pm 15 Ω 1 - 250 MHz
IMPEDANCE, SMOOTHED	100 \pm 10 Ω TYPICAL 5 - 250 MHz
RETURN LOSS	$1 \leq f < 2$ MHz 17 + 9.5 LOG (f) dB MIN $2 \leq f < 10$ MHz 20 + 5 LOG (f) dB MIN $10 \leq f < 20$ MHz 25 dB MIN $20 \leq f \leq 250$ MHz 25 - 8.6 LOG(f/20) dB MIN
PS NEXT	$1 \leq f \leq 250$ MHz 42.3 - 15 LOG(f/100) dB MIN
NEXT	$1 \leq f \leq 250$ MHz 44.3 - 15 LOG(f/100) dB MIN
PSACRF	$1 \leq f \leq 250$ MHz 24.8 - 20 LOG(f/100) dB MIN
ACRF	$1 \leq f \leq 250$ MHz 27.8 - 20 LOG(f/100) dB MIN
INSERTION LOSS	$1 \leq f \leq 250$ MHz 1.95 [1.808 \sqrt{f} + 0.017(f) + 0.2/ \sqrt{f}] dB MAX
DELAY	$1 \leq f \leq 250$ MHz 534 + 36/ \sqrt{f} ns MAX
DELAY SKEW	$1 \leq f \leq 250$ MHz <45 ns MAX
TCL	$1 \leq f \leq 250$ MHz 30 - 10 LOG(f/100) dB MIN
ELTCTL	$1 \leq f \leq 30$ MHz 35 - 20 LOG(f) dB MIN
VELOCITY OF PROPAGATION	68%

Created 11/19/18	DRAWN: SGH 07/21/20
REV. 05	CHECKED: ZRS 07/21/20



TITLE	DATAMAX MINI-6 28 AWG CAT 6 F/UTP PATCH CABLE – TYPE CMP
-------	---

CUSTOMER APPROVAL:

DATE:

DRAWING# QWC0115

2 of 2